

2000h at 85°C

- Features
 - Standard at 85°C
 - RoHS Compliant
- Applications
 - UPS
 - Drive, Inverter



SCREW

Items	Characteristics	
Operating Temperature Range (°C)	-40 ~ +85	-25 ~ +85
Voltage Range (V)	10 ~ 250	350 ~ 500
Capacitance Range (μF)	470 ~ 820000	
Capacitance Tolerance (20°C, 120Hz)	± 20%	
Leakage Current (μA)	After 5 minutes at 20°C application of rated voltage, leakage current is not more than 0.01CV or 5mA, whichever is smaller. C: Nominal Capacitance (μF) V: Rated Voltage (V)	
Dissipation Factor (20°C, 120Hz)	Less than values shown in the standard ratings	

	Useful Life		Load Life	Endurance Test	Shelf Life
Lifetime	>4000h	>65000h	2000h	2000h	1000h
Leakage Current	Not more than specified value		Not more than specified value	Not more than specified value	Not more than specified value
Capacitance Change	Within ± 30% of initial value		Within ± 20% of initial value	Within ± 10% of initial value	Within ± 20% of initial value
Dissipation Factor	Not more than 300% of specified value		Not more than 200% of specified value	Not more than 130% of specified value	Not more than 200% of specified value
Condition: Applied Voltage Applied Current Applied Temperature	U_R I_R 85°C	U_R $1.2 \times I_R$ 40°C	U_R I_R 85°C	U_R $I_R = 0$ 85°C	$U_R = 0$ $I_R = 0$ 85°C After test: U_R to be applied for 60min >24h before measurement

Dimensions

mm

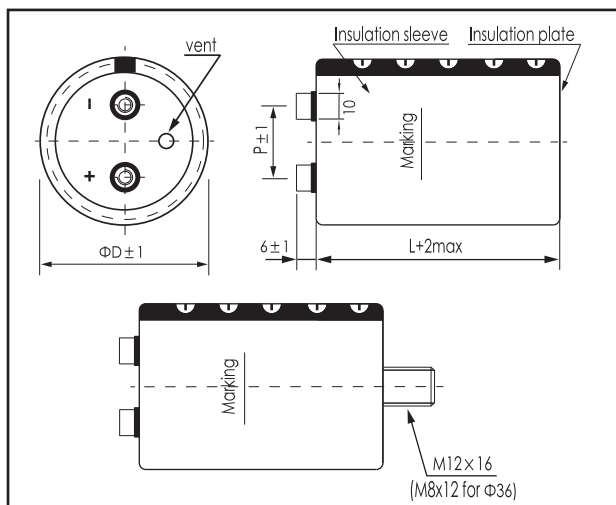

ΦD/mm	36	51	64	77	90
P/mm	12.7	22.0	28.2	31.4	31.4

*Hex head screw M5 x 10 and M6 x 12 are standard screws. Longer screws are available on request.
 *Max tightening torque for screw terminal M5: 3Nm, M6: 4Nm. Max torque for bolt mounting M12: 12.5Nm.
 *Screws, Bracket and cap nut will be delivered separately. See "Accessories" for shape and dimensions.

Part Number System

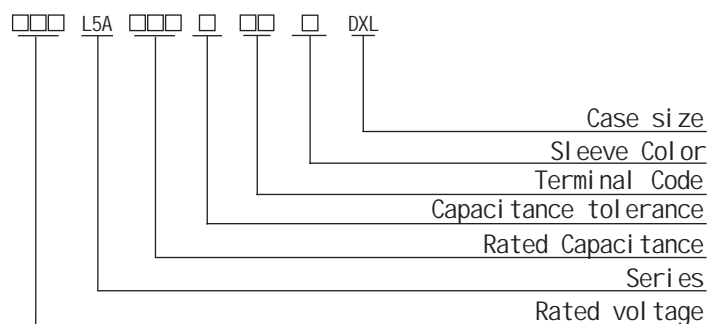

Ripple Current Coefficient

Rated Voltage(V)	Frequency(Hz)				
	50/60	120	300	1k	>10k
10~50	0.95	1.00	1.04	1.10	1.15
63~100	0.95	1.00	1.06	1.16	1.30
160~500	0.80	1.00	1.10	1.25	1.50

Ambient Temp (°C)	40	60	70	85
Coefficient	2.70	2.00	1.70	1.00

The useful life can be prolonged by operating capacitor at loads below the rated values (e.g. lower operating voltage, Rms ripple current or ambient temperature) and by appropriate cooling measures.
 It is advisable not to apply a ripple current exceeding the rated ripple current without any cooling measures as this will shorten capacitor's life.

Ratings for CD 135 Series

U _R (Surge Voltage) Code	Rated Capacitance	Dissipation Factor 20°C, 120Hz	Typ ESR 20°C, 120Hz	Rated Ripple Current 85°C, 120Hz	Size ΦD x L
(V)	(μF)	-	(mΩ)	(Arms)	(mm)
160 (200) 2C	3300	0.25	31	5.2	36 × 121
	4700	0.25	21	5.9	51 × 75
	5600	0.25	19	7.0	51 × 96
	6800	0.25	16	7.8	51 × 96
	10000	0.25	13	10.4	64 × 96
	12000	0.25	10	11.6	51 × 120
	15000	0.25	9	14.3	64 × 130
	18000	0.25	8	15.6	64 × 130
	22000	0.25	6	18.3	77 × 130
	33000	0.25	4	23.8	90 × 131
	39000	0.25	2	27.9	90 × 157
200 (250) 2D	2200	0.25	38	3.9	36 × 100
	3300	0.25	24	4.9	51 × 75
	4700	0.25	20	6.4	51 × 96
	5600	0.25	18	7.6	51 × 115
	6800	0.25	14	8.8	51 × 130
	8200	0.25	11	9.4	64 × 96
	10000	0.25	9	10.4	64 × 96
	15000	0.25	7	14.4	77 × 96
	18000	0.25	6	16.5	77 × 130
	22000	0.25	4	19.6	77 × 155
	33000	0.25	3	25.3	90 × 157
250 (300) 2E	1500	0.25	49	3.2	36 × 100
	2200	0.25	33	4.0	51 × 75
	3300	0.25	23	5.4	51 × 96
	4700	0.25	17	7.1	64 × 96
	6800	0.25	12	9.1	64 × 115
	8200	0.25	11	10.0	64 × 115
	10000	0.25	11	11.7	64 × 130
	15000	0.25	7	15.1	77 × 130
350 (400) 2V	18000	0.25	6	17.7	77 × 155
	22000	0.25	3	20.9	90 × 157
	470	0.2	228	2.2	36 × 83
	680	0.2	152	2.6	36 × 83
	1000	0.2	104	3.4	36 × 100
	1500	0.2	72	4.3	51 × 75
	1800	0.2	58	5.1	51 × 96
	2200	0.2	48	5.7	51 × 96
	2700	0.2	39	7.1	51 × 130
	3300	0.2	32	7.9	51 × 130
400 (450) 2G	3900	0.2	28	9.0	64 × 115
	4700	0.2	25	10.3	64 × 130
	5600	0.2	22	11.4	77 × 115
	6800	0.2	17	13.1	77 × 130
	8200	0.2	14	15.4	77 × 155
	10000	0.2	12	18.1	90 × 157
	12000	0.2	10	20.0	90 × 157
	15000	0.2	8	24.5	90 × 196
	18000	0.2	6	28.8	90 × 236
	470	0.2	178	2.2	36 × 83
680	0.2	119	2.8	36 × 100	
1000	0.2	82	3.5	51 × 75	
1200	0.2	68	3.8	51 × 75	
1500	0.2	58	4.7	51 × 96	
1800	0.2	47	5.2	51 × 96	
2200	0.2	35	6.4	51 × 120	
2700	0.2	33	7.0	64 × 96	
3300	0.2	31	8.2	64 × 115	

U _R (Surge Voltage) Code	Rated Capacitance	Dissipation Factor 20°C, 120Hz	Typ ESR 20°C, 120Hz	Rated Ripple Current 85°C, 120Hz	Size ΦD x L
(V)	(μF)	-	(mΩ)	(Arms)	(mm)
400 (450) 2G	3900	0.2	25	9.4	64 × 130
	4700	0.2	24	10.4	77 × 115
	5600	0.2	19	11.9	77 × 130
	6800	0.2	16	14.1	77 × 155
	8200	0.2	14	16.4	90 × 157
	10000	0.2	11	18.3	90 × 157
	12000	0.2	10	21.8	90 × 196
	15000	0.2	8	26.3	90 × 236
	450 (500) 2W	470	0.2	200	2.2
680		0.2	140	2.8	36 × 100
820		0.2	96	3.2	51 × 75
1000		0.2	82	3.5	51 × 75
1200		0.2	72	4.2	51 × 96
1500		0.2	58	5.1	51 × 115
1800		0.2	46	5.9	51 × 130
2200		0.2	33	6.3	64 × 96
2700		0.2	32	7.5	64 × 115
3300		0.2	30	8.7	64 × 130
3900		0.2	29	9.5	77 × 115
4700		0.2	24	10.9	77 × 130
5600		0.2	16	12.8	77 × 155
6800		0.2	14	15.0	90 × 157
8200		0.2	12	16.5	90 × 157
500 (550) 2H	10000	0.2	10	20.0	90 × 196
	12000	0.2	8	23.6	90 × 236
	1000	0.25	85	4.6	51 × 115
	1500	0.25	60	5.7	64 × 96
	2200	0.25	41	6.9	64 × 130
	2700	0.25	36	8.1	77 × 115
	3300	0.25	32	9.6	77 × 130
	3900	0.25	30	10.8	77 × 130
	4700	0.25	27	12.1	77 × 155
	5600	0.25	21	13.8	90 × 157
6800	0.25	18	15.8	90 × 171	
8200	0.25	14	17.2	77 × 220	
10000	0.25	10	22.1	90 × 236	

SCREW

Mounting code(" B" for bolt mounting, "Y/I/N" for bracket mounting)
Terminal options(A,B,C see "Dimensions" for details.)

Lifetime Diagram

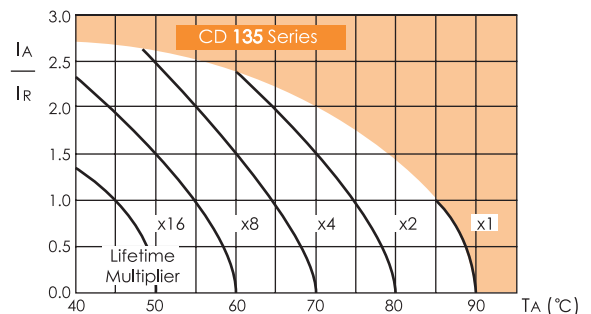

I_A = Actual ripple current at 120Hz;
I_R = Rated ripple current at 120Hz, 85°C;
T_A = Ambient temperature

Ratings for CD 135 Series

SCREW

U _r (Surge Voltage) Code	Rated Capacitance	Dissipation Factor 20°C, 120Hz	Typ ESR 20°C, 120Hz	Rated Ripple Current 85°C, 120Hz	Size ΦD x L
(V)	(μF)	-	(mΩ)	(Arms)	(mm)
10 (13) 1A	33000	0.80	21	4.3	36×53
	39000	0.80	18	4.7	36×53
	47000	0.80	15	5.2	36×65
	56000	0.80	13	6.1	36×83
	68000	0.80	10	6.7	36×83
	82000	0.80	9	7.7	36×100
	100000	0.80	8	8.8	36×100
	120000	0.80	7	10.0	36×121
	150000	1.00	7	10.8	36×121
	180000	1.00	6	12.0	51×96
	220000	1.50	5	11.2	51×121
	270000	1.50	4	12.8	51×121
	330000	1.50	4	15.3	64×96
	390000	1.50	3	17.3	64×115
	470000	2.00	3	16.7	64×130
	560000	2.00	3	19.0	77×115
680000	2.00	3	21.7	77×130	
820000	2.00	2	24.7	77×155	
16 (20) 1C	22000	0.60	22	4.1	36×53
	27000	0.60	19	4.5	36×53
	33000	0.60	16	5.0	36×53
	39000	0.60	13	5.9	36×65
	47000	0.60	11	6.4	36×83
	56000	0.60	10	7.3	36×83
	68000	0.60	8	8.4	36×100
	82000	0.80	7	8.3	36×100
	100000	0.80	6	9.5	36×121
	120000	0.80	5	10.9	36×121
	150000	1.00	4	11.3	51×96
	180000	1.00	3	12.8	51×115
	220000	1.00	3	15.3	51×130
	270000	1.00	3	17.6	64×96
	330000	1.50	3	16.8	64×115
	390000	1.50	3	18.3	64×130
470000	1.50	2	21.3	77×115	
560000	1.50	2	23.6	77×130	
680000	1.50	2	27.6	77×155	
820000	2.00	2	27.1	90×157	
25 (32) 1E	15000	0.50	22	3.7	36×53
	18000	0.50	18	4.1	36×53
	22000	0.50	16	4.5	36×53
	27000	0.50	13	5.0	36×65
	33000	0.50	11	5.9	36×83
	39000	0.50	9	6.7	36×83
	47000	0.50	8	7.7	36×100
	56000	0.60	7	7.9	36×100
	68000	0.60	6	9.1	36×121
	82000	0.60	5	10.4	36×121
	100000	0.80	4	10.3	51×96
	120000	0.80	4	11.7	51×115
	150000	0.80	3	14.1	51×130
	180000	0.80	3	15.7	64×96
	220000	1.00	3	16.1	64×115
	270000	1.00	3	18.6	64×130
330000	1.00	2	21.9	64×155	
390000	1.20	2	22.0	77×115	
470000	1.20	2	25.6	77×155	
560000	1.20	2	27.9	90×131	
680000	1.20	2	32.5	90×157	
35 (44) 1V	10000	0.40	24	3.4	36×53
	12000	0.40	20	3.7	36×53
	15000	0.40	17	4.2	36×65
	18000	0.40	14	4.9	36×83
	22000	0.40	12	5.7	36×83
	27000	0.40	9	6.3	36×100
	33000	0.40	9	7.2	36×100
	39000	0.50	8	7.3	36×121
	47000	0.50	8	8.7	51×96
	56000	0.60	8	8.6	51×96
	68000	0.60	6	9.8	51×115
	82000	0.60	5	11.6	64×96
	100000	0.60	4	13.3	64×115
	120000	0.60	4	14.8	64×121
	150000	0.80	4	14.9	64×130
	180000	0.80	3	17.0	77×115
220000	0.80	3	20.0	77×130	

U _r (Surge Voltage) Code	Rated Capacitance	Dissipation Factor 20°C, 120Hz	Typ ESR 20°C, 120Hz	Rated Ripple Current 85°C, 120Hz	Size ΦD x L
(V)	(μF)	-	(mΩ)	(Arms)	(mm)
35 (44) 1V	270000	1.00	3	20.3	77×155
	330000	1.00	2	23.5	90×131
	390000	1.00	2	26.4	90×157
	470000	1.00	2	29.6	90×157
	56000	0.30	46	3.0	36×53
50 (63) 1H	6800	0.30	38	3.3	36×53
	8200	0.30	31	3.6	36×53
	10000	0.30	26	4.0	36×65
	12000	0.30	22	4.7	36×83
	15000	0.30	15	5.5	36×83
	18000	0.30	12	6.2	36×100
	22000	0.40	11	6.3	36×121
	27000	0.40	10	7.1	36×121
	33000	0.40	9	8.2	51×96
	39000	0.50	8	8.1	51×96
	47000	0.50	8	9.3	51×115
	56000	0.50	6	10.5	64×96
	68000	0.50	5	12.0	64×96
	82000	0.50	4	13.7	64×115
	100000	0.60	4	14.7	77×115
	120000	0.60	3	16.7	77×115
150000	0.60	3	19.3	77×130	
180000	0.60	3	21.9	77×155	
220000	0.60	2	21.4	90×131	
270000	0.60	2	24.6	90×157	
63 (79) 1J	3900	0.25	47	2.7	36×53
	4700	0.25	39	3.0	36×53
	5600	0.25	38	3.3	36×53
	6800	0.25	32	3.6	36×65
	8200	0.25	26	4.3	36×83
	10000	0.25	23	4.9	36×83
	12000	0.25	18	5.6	36×100
	15000	0.30	16	5.9	36×100
	18000	0.30	15	6.7	36×121
	22000	0.30	13	7.8	36×121
	27000	0.40	12	7.4	51×96
	33000	0.40	8	8.4	51×96
	39000	0.40	7	9.5	51×115
	47000	0.40	6	11.3	51×130
	56000	0.40	6	12.8	64×115
	68000	0.50	5	12.7	64×121
82000	0.50	4	14.5	64×130	
100000	0.50	4	16.7	77×115	
120000	0.50	3	18.9	77×130	
150000	0.50	2	22.4	77×155	
180000	0.60	2	22.4	90×131	
220000	0.60	2	26.2	90×157	
80 (100) 1K	3300	0.25	54	2.5	36×53
	3900	0.25	46	2.8	36×53
	4700	0.25	38	3.0	36×65
	5600	0.25	32	3.6	36×83
	6800	0.25	26	3.9	36×83
	8200	0.25	22	4.5	36×83
	10000	0.25	17	5.2	36×100
	12000	0.25	15	5.9	36×100
	15000	0.25	12	6.8	36×121
	18000	0.25	10	7.8	36×121
	22000	0.30	10	8.0	51×96
	27000	0.30	8	9.2	51×96
	33000	0.30	7	10.5	51×115
	39000	0.30	6	12.0	51×130
	47000	0.30	5	13.6	64×115
	56000	0.40	4	13.4	64×130
68000	0.40	4	15.4	77×115	
82000	0.40	4	17.5	77×130	
100000	0.40	3	20.5	77×155	
120000	0.40	2	22.4	90×131	
150000	0.40	2	26.5	90×157	
100 (125) 2A	1800	0.25	48	1.9	36×53
	2200	0.25	44	2.1	36×53
	2700	0.25	39	2.3	36×53
	3300	0.25	35	2.6	36×65
	3900	0.25	28	3.0	36×83
	4700	0.25	26	3.5	36×83
	5600	0.25	23	3.9	36×100
	6800	0.25	22	4.5	36×100
	8200	0.25	20	5.1	36×121
	10000	0.25	19	5.9	36×121
	12000	0.25	16	6.4	51×75
	15000	0.25	12	7.0	51×96
	18000	0.25	10	8.3	51×115
	22000	0.25	8	10.0	51×130
	27000	0.25	7	11.5	64×115
	33000	0.25	6	11.9	64×130
39000	0.25	5	13.4	77×115	
47000	0.35	5	14.2	77×130	
56000	0.35	4	16.0	77×155	
68000	0.35	3	18.8	90×131	
82000	0.35	3	20.5	90×157	
100000	0.35	3	24.0	90×171	

Mounting code(" B" for bolt mounting, "Y/I/N" for bracket mounting)
Terminal options(A B C see "Dimensions" for details)